

**PERFORM
WITH
PRECISION**

**ADJUSTABLE
COLUMN FORM**

**CONCRETE
FORMING
SYSTEM**

BROCHURE



SYMONS[®]
By Dayton Superior



Civil and Commercial Column Dimensions

Symons Adjustable Column Form system is the system to use for square and rectangular columns up to 48". It is designed to form a variety of column dimensions using identical panels, ensuring versatility and productivity. There are adjustment combinations to match any column design.

Heavy Duty

Symons recognizes the need for durable, rugged forming equipment. The Adjustable Column forming system is no exception. The system is built to stand up to the daily punishment of any forming project with a design rating of 2000 pounds per square foot, using Symons standard 3/4" Speed Bolts.

- Strong 2000 psf system
- Rugged 3/16" steel face
- Convenient 2'-0" bolt centers



Excellent Concrete Finish

Unlike other column forming systems, Symons uses 3/16" steel plate for the forming surface. The heavier plate results in the benefits of faster pour rate, less deflection and excellent concrete finish.

In addition, the system requires no internal ties, eliminating the associated material and labor costs.

The finish achieved with this system eliminates most finishing steps necessary to provide an architectural finish.

- Built-in 3/4" steel chamfer for standardized corners
- Reduce tie hole plugging with no internal ties up to 48"
- Flush hole plugs provide a predictable surface

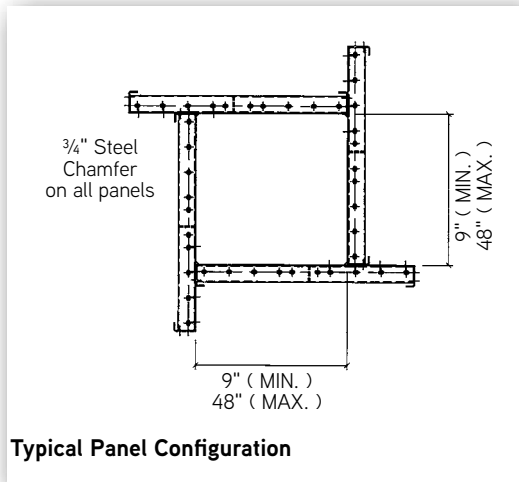

Built-In versatility

An extraordinary 295 column configurations are possible with just four panel widths.

The ability to form 10" square to 48" square columns with a minimum of panels is a cost saving benefit to contractors. Add to that the versatility to form rectangular configurations in 1" or 2" increments, and you have a truly versatile and highly productive concrete column forming system.

- 24", 36", 48" panel widths adapt to any infrastructure or commercial project dimension requirements
- 1', 2', 4', 8', 12' panel heights combine to create any column height required

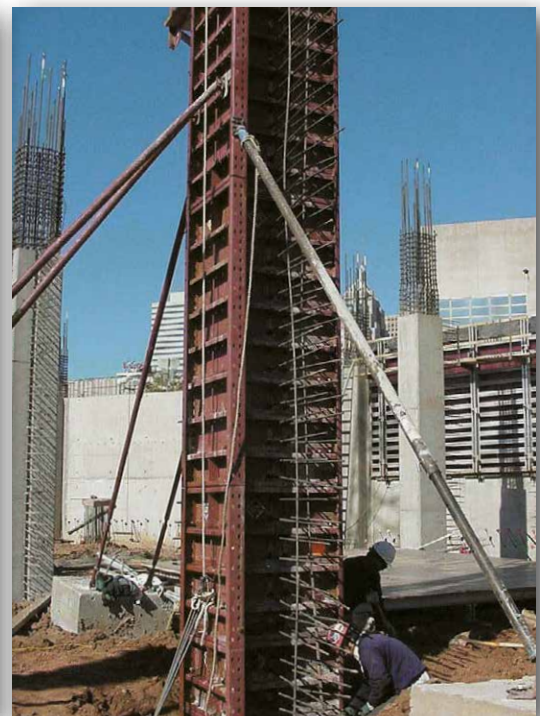



DAYTON[®]
SUPERIOR

1125 Byers Road
Miamisburg, OH 45342
937-866-0711
888-977-9600

**PERFORM
WITH
PRECISION**

SYM116
02/16

Copyright © 2016 Dayton Superior Corporation, All Rights Reserved.